



**Opto Plus LED Corp.**  
**0.28" SMD Type LED Display**  
**OPS-S2812SB-GW**  
**OPS-S2811SB-GW**

● **EDIT HISTORY**

Version A: Oct. 28, 2015

Preliminary Spec.

Manufacture	Examination	Approving



**Opto Plus LED Corp.**  
**0.28" SMD Type LED Display**  
**OPS-S2812SB-GW**  
**OPS-S2811SB-GW**

● **FEATURES**

- 0.28 inch (7.00 mm) Digit Height.
- SMD type.
- Low current operation.
- Gray face, White segment.
- RoHS compliant, Pb Free.

● **DESCRIPTION**

The OPS-S2812LB-GW & OPS-S2811LB-GW are 0.28 inch (7.00 mm) height Single digit 7-segment displays.

This device utilizes Super Bright Blue LED chip which are made from InGaN On a transparent GaN, substrate.

The display has Gray face, White segment.

● **DEVICE**

PART NO	DESCRIPTION
OPS-S2812LB-GW	Common Anode
OPS-S2811LB-GW	Common Cathode

**RoHS Compliance**



**Pb free.**



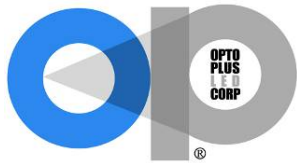

**Opto Plus LED Corp.**  
**0.28" SMD Type LED Display**  
**OPS-S2812SB-GW**  
**OPS-S2811SB-GW**

● **MECHANICAL DIMENSIONS**

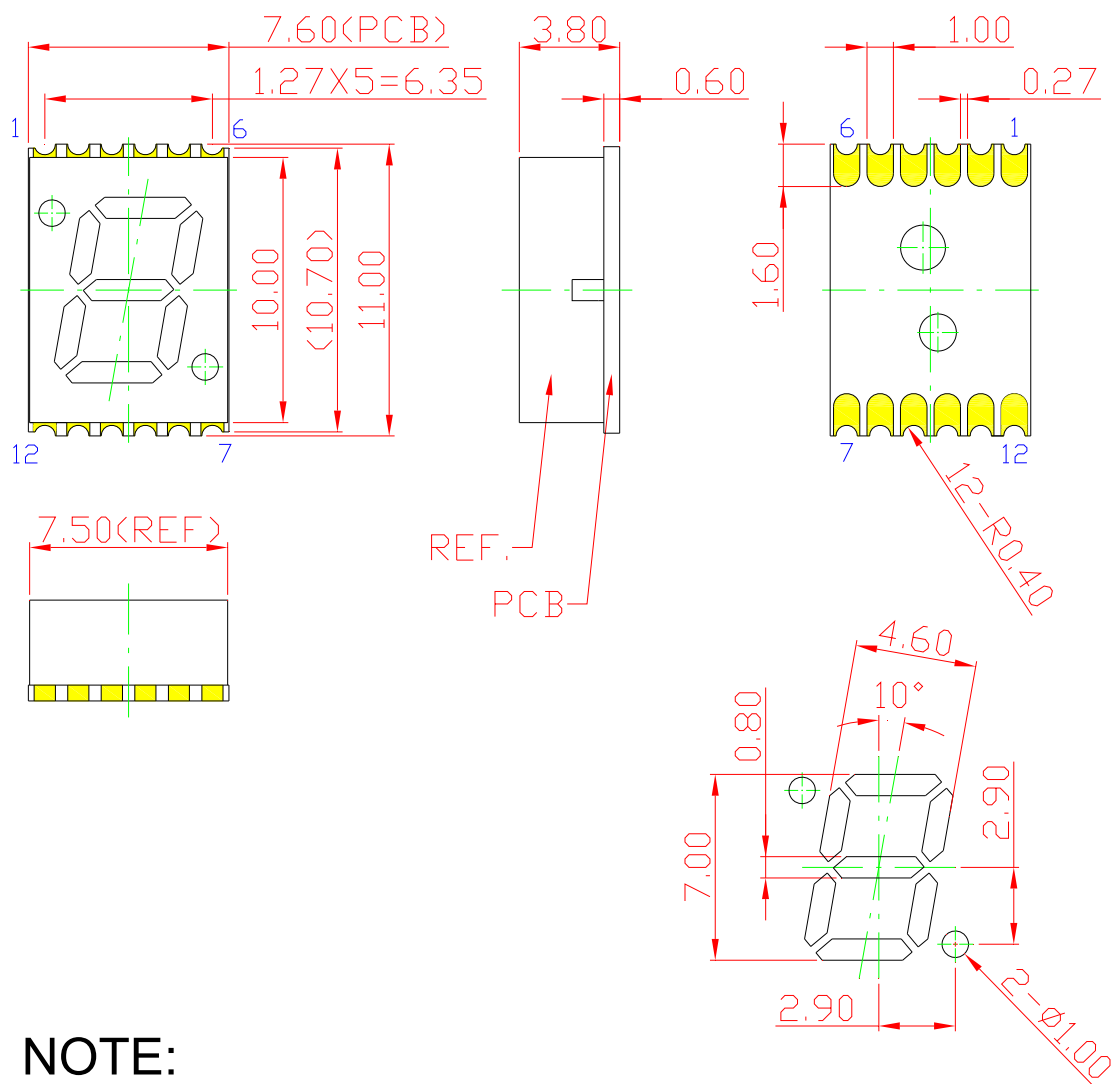

**NOTE:**  
 Dimension in millimeters (inches),  
 and tolerances are  $\pm 0.25\text{mm}$  (.01") specified.

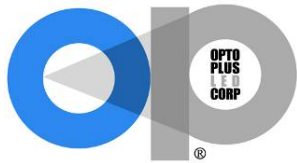

**Opto Plus LED Corp.**  
**0.28" SMD Type LED Display**  
**OPS-S2812SB-GW**  
**OPS-S2811SB-GW**

● **TYPICAL INTERNAL EQUIVALENT CIRCUIT**

**Recommended  
Soldering Pattern**

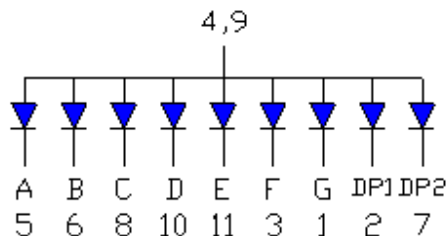
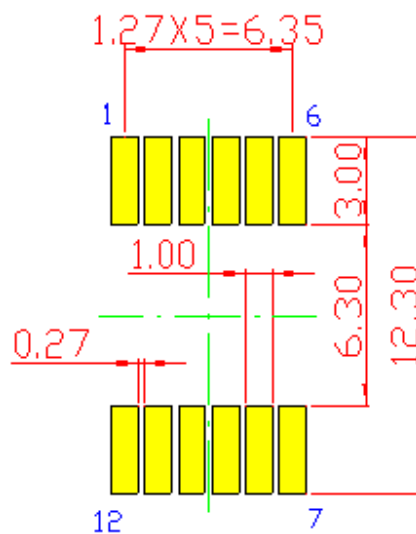
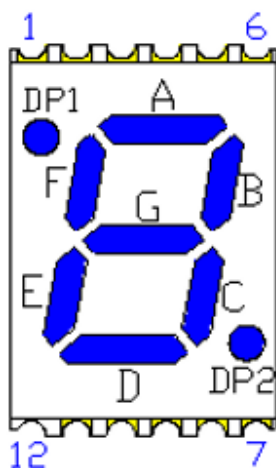

12 PIN No Connect  
**OPS-S2812SB-GW (Common Anode)**

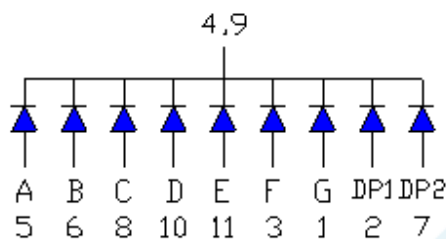

12 PIN No Connect  
**OPS-S2811SB-GW (Common Cathode)**



**Opto Plus LED Corp.**  
**0.28'' SMD Type LED Display**  
**OPS-S2812SB-GW**  
**OPS-S2811SB-GW**

● **SB: SUPER BRIGHT BLUE (InGaN/GaN)**

ABSOLUTE MAXIMUM RATING AT Ta=25°C

Parameter	Symbol	Maximum Rating	Unit
Power dissipation	$P_{AD}$	120	mW
Derating liner from 25°C	-	0.3	mA / °C
Continuous forward current	$I_{AF}$	30	mA
Peak current (duty cycle 1/10, 1kHz)	$I_{PF}$	100	mA
Reverse voltage	$V_R$	5	V
Operating temperature	$T_{OPR}$	-40 to +105	°C
Storage temperature	$T_{STG}$	-40 to +105	°C

ELECTRICAL - OPTICAL CHARACTERISTICS AT Ta=25°C

Characteristic	Symbol	Condition	Min.	Type.	Max.	Unit
Forward Voltage, (Per Dice)	$V_F$	$I_F = 20\text{mA}$	-	3.2	4.0	V
Reverse Current, (Per Dice)	$I_R$	$V_R = 8\text{V}$	-	-	10	$\mu\text{A}$
Dominant Wavelength	$\lambda_D$	$I_F = 20\text{mA}$	464	-	474	nm
Luminous Intensity	$I_V$	$I_F = 20\text{mA}$	20	-	60	mcd
Spectral radiation bandwidth	$\Delta\lambda$	$I_F = 20\text{mA}$	-	30	-	nm



**Opto Plus LED Corp.**  
**0.28" SMD Type LED Display**  
**OPS-S2812SB-GW**  
**OPS-S2811SB-GW**

● **SB: BIN GRADE (Unit : mcd ) 20mA**

Super Bright Blue	L	M	N
	20.0 ~ 32.0	32.1 ~ 45.0	45.1~60.0

● **LB: HUE GRADE ( $\lambda D$  : nm)**

1	2	3
464.0 ~ 467.0	467.1 ~ 470.0	470.1~ 474.0

● **AVAILABLE BIN / HUE TABLE**

L1	M1	N1
L2	M2	N2
L3	M3	N3

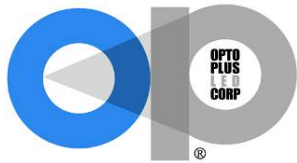

# Opto Plus LED Corp.

## 0.28" SMD Type LED Display

### OPS-S2812SB-GW

### OPS-S2811SB-GW

#### ● SB: SUPER BRIGHT BLUE (InGaN/GaN) CURVE

Typical Electro-optical Characteristic Curves  
(25 °C Free Air Temperature Unless Otherwise Specified)

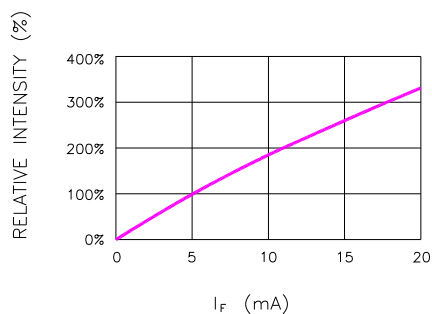

Fig.1 RELATIVE INTENSITY VS. FORWARD CURRENT

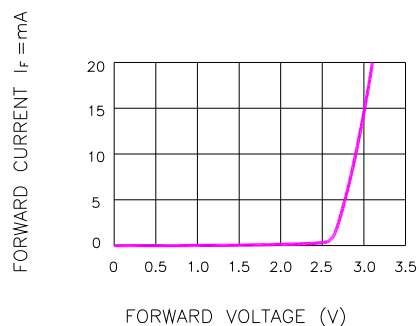

Fig.2 FORWARD CURRENT VS. FORWARD VOLTAGE

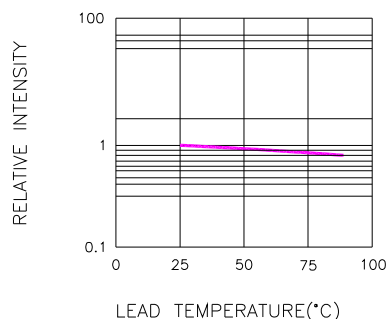

Fig.3 RELATIVE INTENSITY VS. LEAD TEMPERATURE  
(PULSED 20 mA; 300us PULSE, 10ms PERIOD)

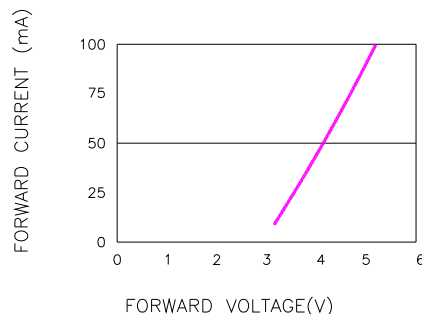

Fig.4 PEAK FORWARD VOLTAGE VS. FORWARD (100us TEST PULSE, 1% DUTY CYCLE)

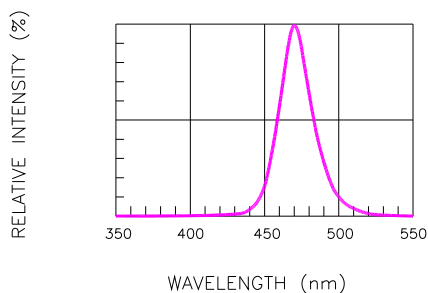

Fig.5 RELATIVE INTENSITY VS. WAVELENGTH

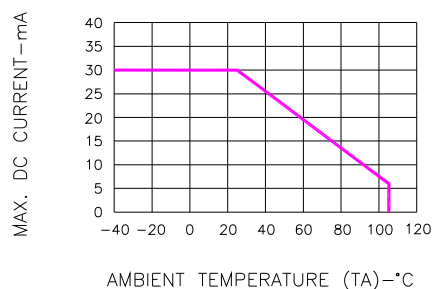

Fig.6 MAX. ALLOWABLE DC CURRENT VS. AMBIENT TEMPERATURE

Version: A Date: 10/28/2015

Opto Plus LED Corp. 7F-3, No.496, Bannan Road, Zhonghe Dist., New Taipei City 235, Taiwan (R.O.C)

Website: [www.opled.com.tw](http://www.opled.com.tw) E-mail: [sales@opled.com.tw](mailto:sales@opled.com.tw) Tel: 886-2-2222-5698 Fax: 886-2-2222-2566



**Opto Plus LED Corp.**  
**0.28" SMD Type LED Display**  
**OPS-S2812SB-GW**  
**OPS-S2811SB-GW**

● **SMT REFLOW SOLDERING INSTRUCTIONS**

SMT Soldering Profile

Pb free reflow soldering Profile

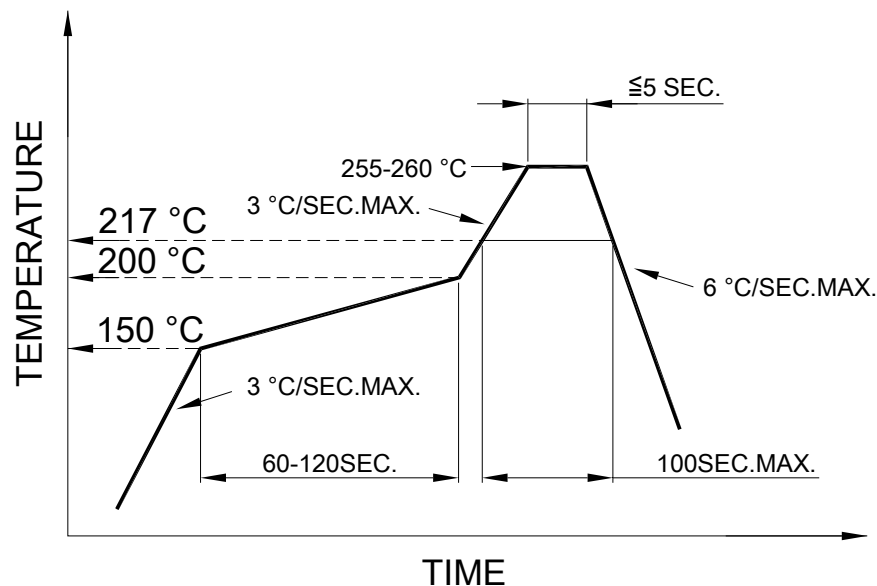

- We recommend the reflow temperature 245°C (+/- 5°C).  
The maximum soldering temperature should be limited to 260°C.
- Number of reflow process shall be 2 times or less.

● **SOLDERING IRON**

Basic spec is  $\leq 4$  sec when 260°C. If temperature is higher, time should be shorter (+10°C → 1 sec). Power dissipation of Iron should be smaller than 15W, and temperature should be controllable. Surface temperature of the device should be under 230°C.

● **REWORK**

- Customer must finish rework within 3 sec. under 350°C.
- The head of soldering iron cannot touch copper foil.





# Opto Plus LED Corp.

## 0.28" SMD Type LED Display

### OPS-S2812SB-GW

### OPS-S2811SB-GW

#### ● REEL DIMENSIONS

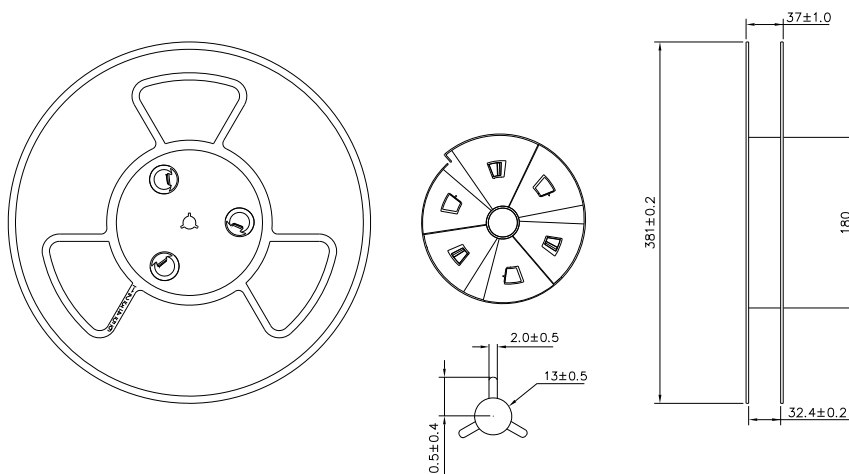

#### ● PACKING & LABEL SPECIFICATIONS

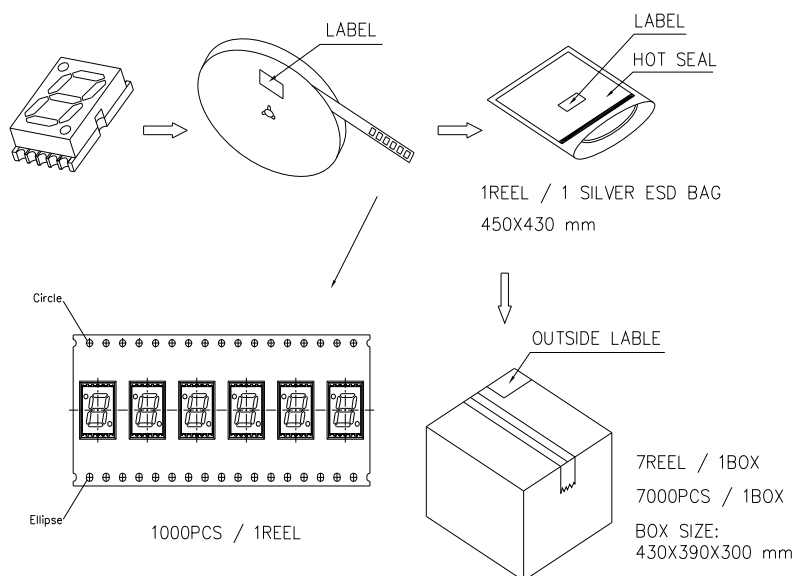

#### ● STORAGE CONDITION

In factory original sealed bag package

TEMPERATURE CONDITION	HUMIDITY CONDITION
5°C ~ 30°C	Below 60%RH

After opened and not in factory original sealed bag package

TEMPERATURE CONDITION	HUMIDITY CONDITION	STORAGE TIME
5°C ~ 30°C	Below 60%RH	Within 4 weeks (MSL as level 2a)

Version: A Date: 10/28/2015

Opto Plus LED Corp. 7F-3, No.496, Bannan Road, Zhonghe Dist., New Taipei City 235, Taiwan (R.O.C)

Website: [www.opled.com.tw](http://www.opled.com.tw) E-mail: [sales@opled.com.tw](mailto:sales@opled.com.tw) Tel: 886-2-2222-5698 Fax: 886-2-2222-2566