



Opto Plus LED Corp

OPS-L955MWC-ZS

3.5 x 2.8 x 1.9 mm PLCC2

● **EDIT HISTORY**

Version A: Sep. 27, 2011

New color data sheet.

Manufacture	Examination	Approving



Opto Plus LED Corp

OPS-L955MWC-ZS

3.5 x 2.8 x 1.9 mm PLCC2

● FEATURES

- ◆ 3.5 x 2.8 x 1.9 mm PLCC2.
- ◆ Wide viewing angle.
- ◆ Low current requirement.
- ◆ IR reflow soldering.
- ◆ I.C. compatible

● PACKAGE DIMENSIONS

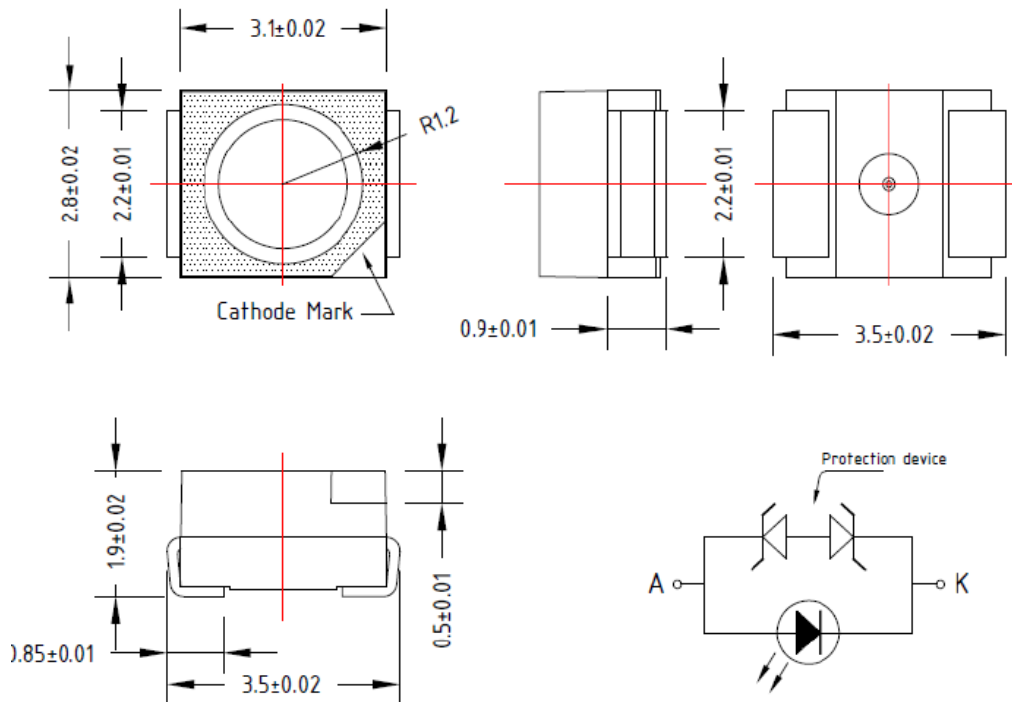

NOTES:

1. All dimensions are in millimeters (inches);
2. Electrical Connection between all Cathodes is Recommended

LENS COLOR	DICE MATERIAL	LIGHT COLOR
Yellow	InGaN	White

RoHS Compliance



Pb free.





Opto Plus LED Corp

OPS-L955MWC-ZS

3.5 x 2.8 x 1.9 mm PLCC2

● ABSOLUTE MAXIMUM RATINGS AT TA=25°C

Parameter	Symbol	Ultra Bright Red	Unit
Power Dissipation	P_{AD}	105	mW
Continuous Forward Current	I_{FMAX}	30	mA
Peak Forward Current (duty cycle 1/10, 0.1ms Pulse Width)	I_{FP}	100	mA
Reverse Voltage	V_R	5	V
Operating Temperature Range	T_{OPR}	-30 to +100	°C
Storage Temperature Range	T_{STG}	-40 to +100	°C
Solder Temperature	T_{SOL}	265°C for 10sec	

I_{FP} Conditions: Pulse Width ≤ 10msec and Duty ≤ 1/10

● ELECTRICAL OPTICAL CHARACTERISTICS AT TA=25°C

Characteristic	Symbol	Condition	Min.	Type	Max.	Unit
Forward Voltage	V_F	$I_F = 20mA$	-	3.1	3.5	V
Reverse Current	I_R	$V_R = 5V$	-	-	10	μA
Chromaticity Coordinate	X	$I_F = 25mA$	-	0.31	-	nm
Chromaticity Coordinate	Y	$I_F = 25mA$	-	0.32	-	nm
Luminous Intensity	I_V	$I_F = 20mA$	1800	2300	2800	mcd

Notes: Luminous intensity tolerance is 10%



Opto Plus LED Corp

OPS-L955MWC-ZS

3.5 x 2.8 x 1.9 mm PLCC2

● LUMINOUS INTENSITY BIN LIMITS

Test condition : @20mA		
BIN Code	I _v min. (mcd)	I _v max. (mcd)
1	1800	2000
2	2000	2200
3	2200	2400
4	2400	2600
5	2600	2800

* @20mA / Ta=25°C, Tolerance: ±15%

● FORWARD VOLTAGE BIN LIMITS

Test condition : @20mA		
Color	Bin Code	Spec. Range (V)
White	A	2.9 – 3.0
	B	3.0 – 3.1
	C	3.1 – 3.2
	D	3.2 – 3.3
	E	3.3 – 3.4
	F	3.4 – 3.5

* @20mA / Ta=25°C, Tolerance: ±0.05V



Opto Plus LED Corp

OPS-L955MWC-ZS

3.5 x 2.8 x 1.9 mm PLCC2

Chromaticity Diagram

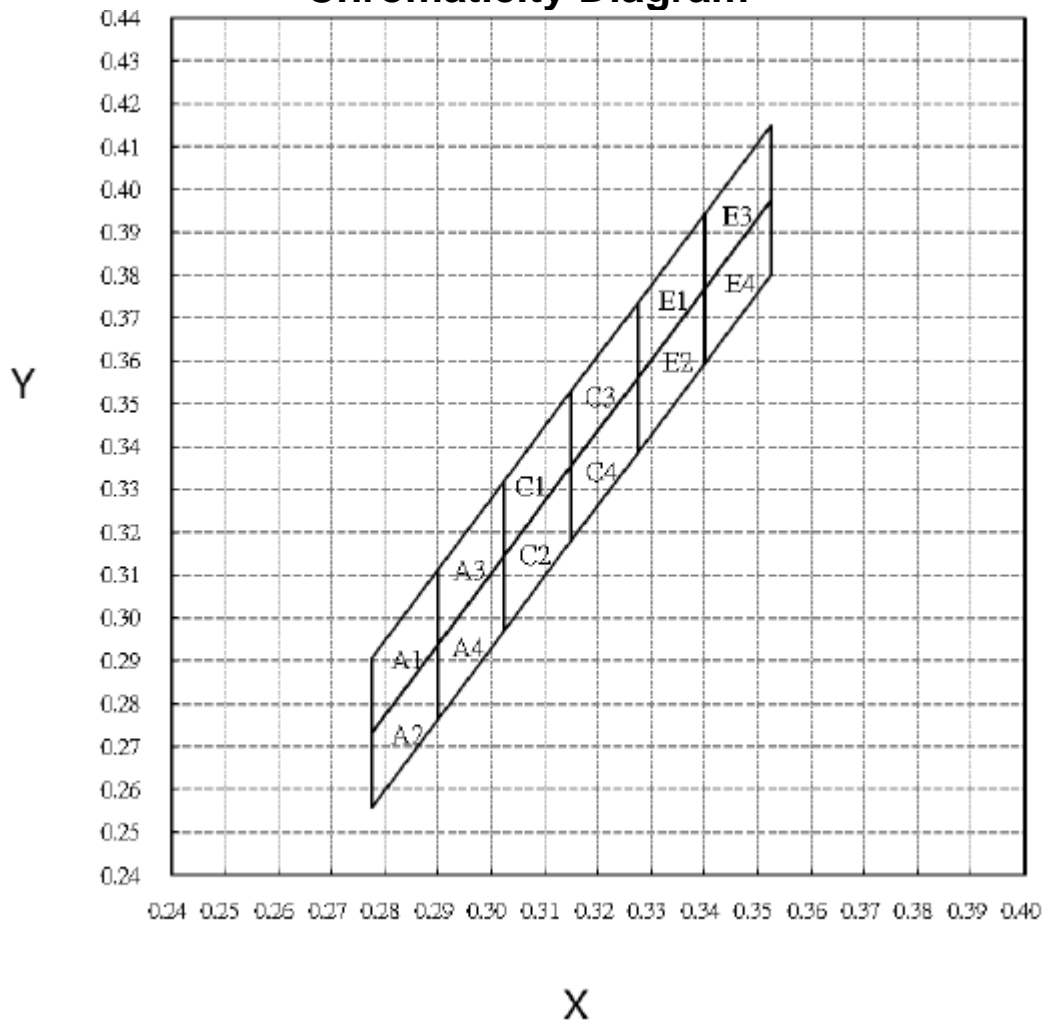



Opto Plus LED Corp

OPS-L955MWC-ZS

3.5 x 2.8 x 1.9 mm PLCC2

Color Ranks

BIN A1					BIN A2				
X	0.2775	0.2900	0.2900	0.2775	X	0.2775	0.2900	0.2900	0.2775
Y	0.2732	0.2939	0.3114	0.2907	Y	0.2557	0.2764	0.2939	0.2732
BIN A3					BIN A4				
X	0.2900	0.3025	0.3025	0.2900	X	0.2900	0.3025	0.3025	0.2900
Y	0.2939	0.3146	0.3321	0.3114	Y	0.2764	0.2971	0.3146	0.2939
BIN C1					BIN C2				
X	0.3025	0.3150	0.3150	0.3025	X	0.3025	0.3150	0.3150	0.3025
Y	0.3146	0.3354	0.3529	0.3321	Y	0.2971	0.3179	0.3354	0.3146
BIN C3					BIN C4				
X	0.3150	0.3275	0.3275	0.3150	X	0.3150	0.3275	0.3275	0.3150
Y	0.3354	0.3561	0.3736	0.3529	Y	0.3179	0.3386	0.3561	0.3354
BIN E1					BIN E2				
X	0.3275	0.3400	0.3400	0.3275	X	0.3275	0.3400	0.3400	0.3275
Y	0.3561	0.3768	0.3943	0.3736	Y	0.3386	0.3593	0.3768	0.3561
BIN E3					BIN E4				
X	0.3400	0.3525	0.3525	0.3400	X	0.3400	0.3525	0.3525	0.3400
Y	0.3768	0.3975	0.415	0.3943	Y	0.3593	0.3800	0.3975	0.3768

Note

- One delivery will include several color ranks and I_v ranks of products.
The quantity-ratio of the different rank is decided by OP.
- Bin Name typed on the Label: IV RANK + Color Rank + VF RANK
For Example, BIN I-A1-A Means IV: 1800~2000mcd, Color Bin:A1, and VF: 2.9~3.0V.
Color Coordinates Measurement Allowance is ± 0.01
- 2000 pcs per reel



Opto Plus LED Corp

OPS-L955MWC-ZS

3.5 x 2.8 x 1.9 mm PLCC2

OPTICAL CHARACTERISTIC CURVES:

Forward Current vs. Forward Voltage

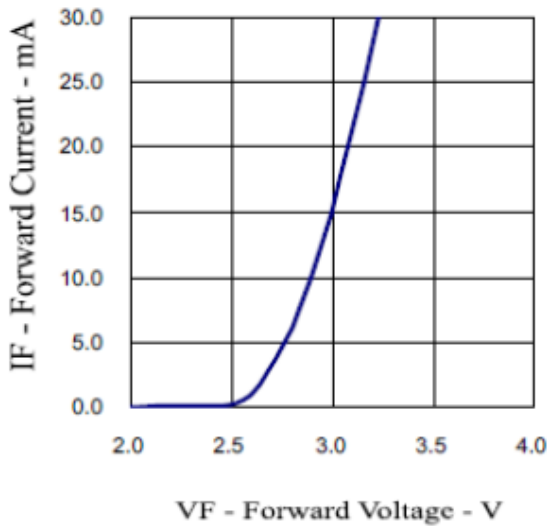

Relative Intensity vs. Forward Current

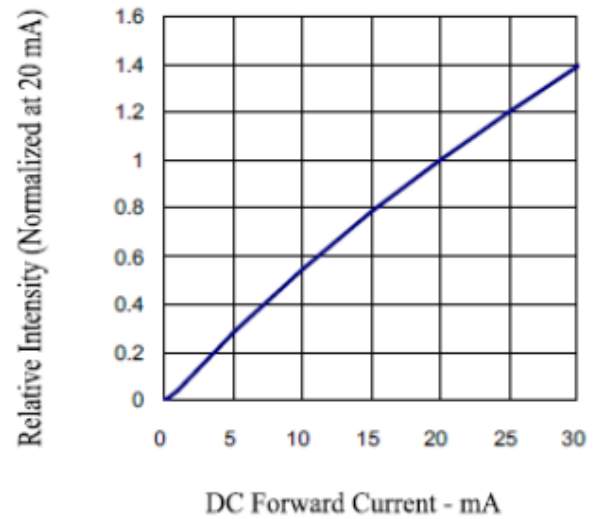

Forward Current vs. Ambient Temperature

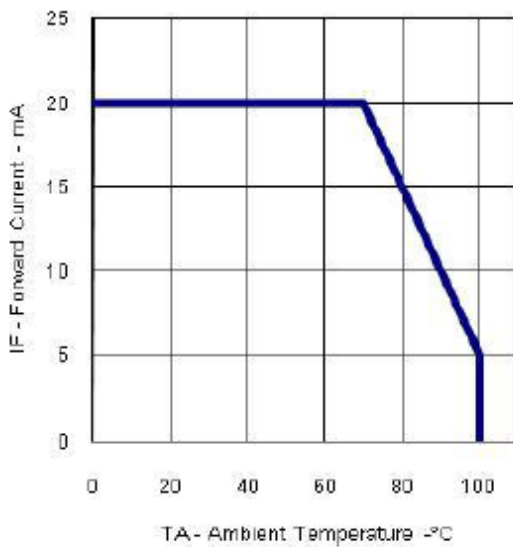

Relative Intensity vs. Wavelength

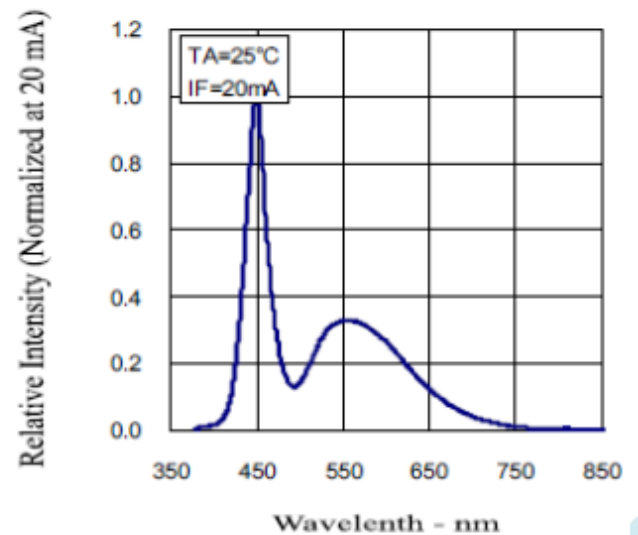



Opto Plus LED Corp

OPS-L955MWC-ZS

3.5 x 2.8 x 1.9 mm PLCC2

Radiation Pattern

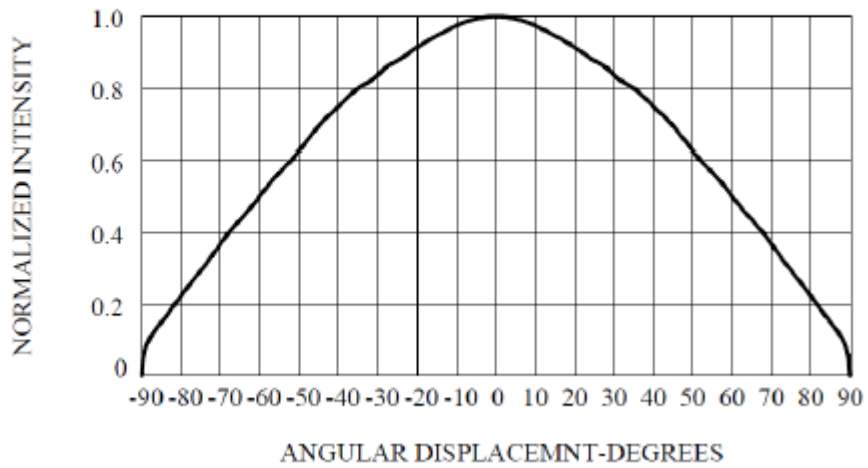

Recommended Soldering Pad Pattern

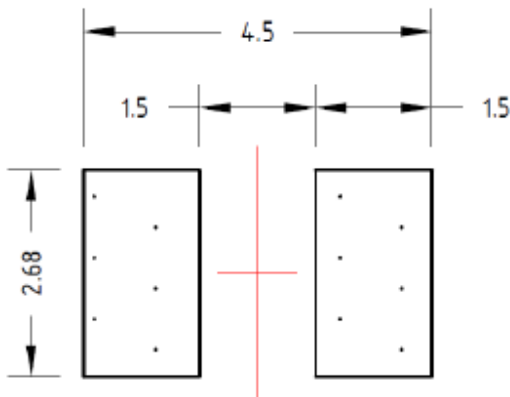

(Unit:mm)

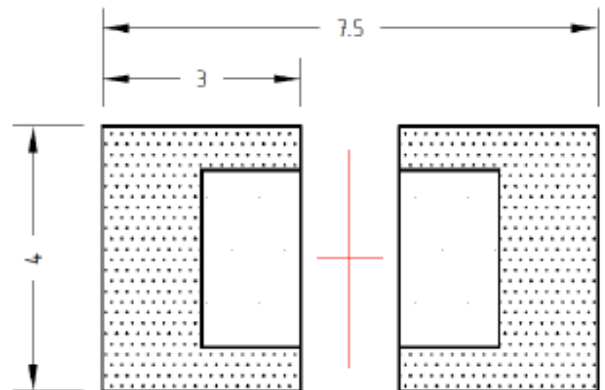

(Unit:mm)



Opto Plus LED Corp

OPS-L955MWC-ZS

3.5 x 2.8 x 1.9 mm PLCC2

Soldering Conditions:

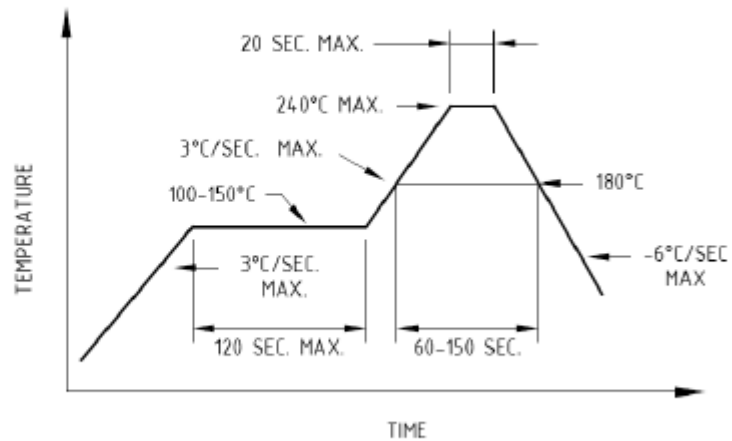

Recommended reflow soldering profile

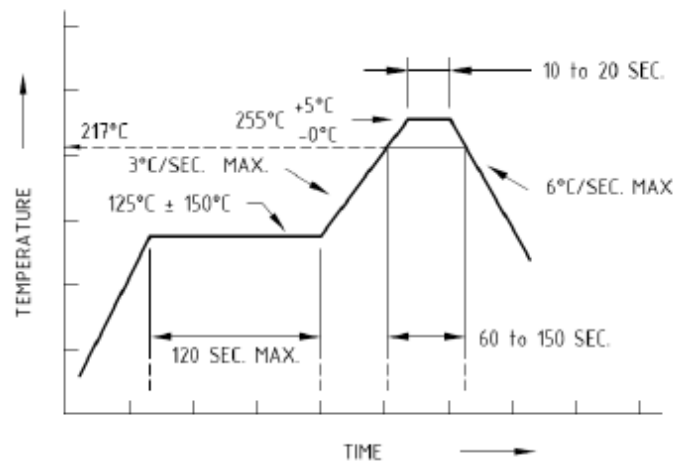

Recommended Pb-free reflow soldering profile

- Repairing should not be done after the LEDs have been soldered. When repairing is unavoidable, a double-head soldering iron should be used. It should be confirmed beforehand whether the characteristics of the LEDs will or will not be damaged by repairing.
- Reflow soldering should not be done more than two times.
- When soldering, do not put stress on the LEDs during heating.
- After soldering, do not warp the circuit board.



Opto Plus LED Corp

OPS-L955MWC-ZS

3.5 x 2.8 x 1.9 mm PLCC2

Tape Dimension

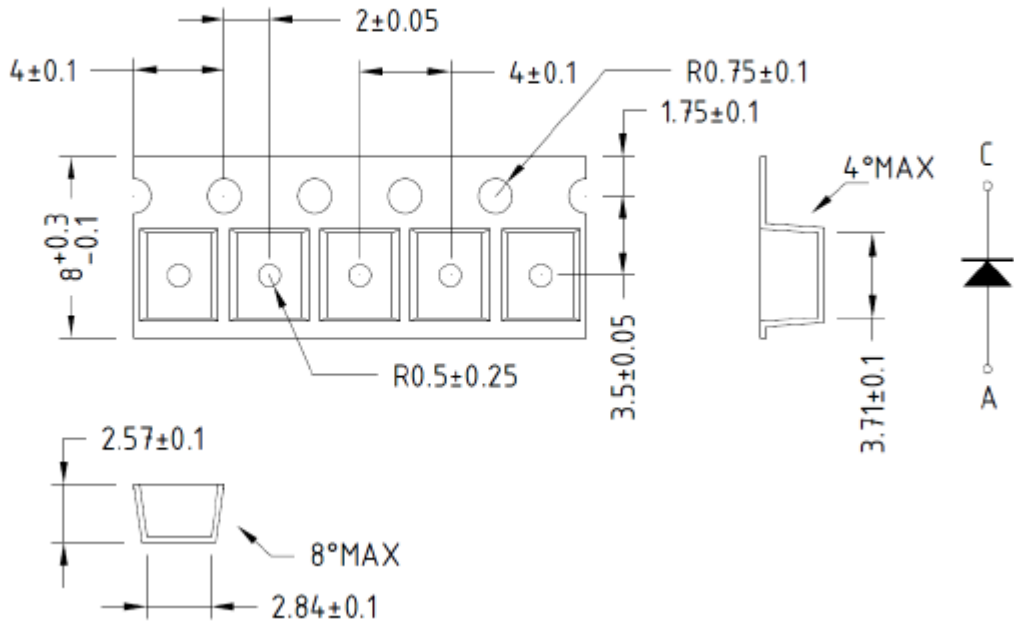

Tape Leader and Trailer Dimension

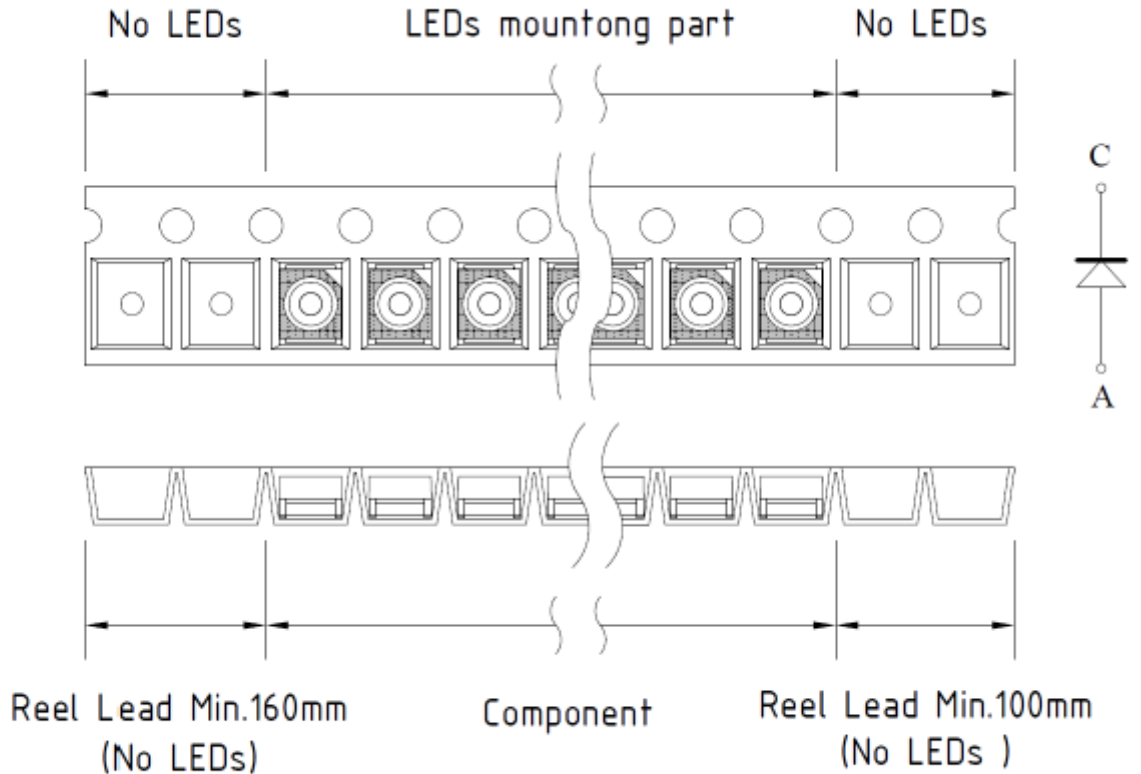

USER FEED DIRECTION



Opto Plus LED Corp

OPS-L955MWC-ZS

3.5 x 2.8 x 1.9 mm PLCC2

● PACKAGE DIMENSIONS OF REEL

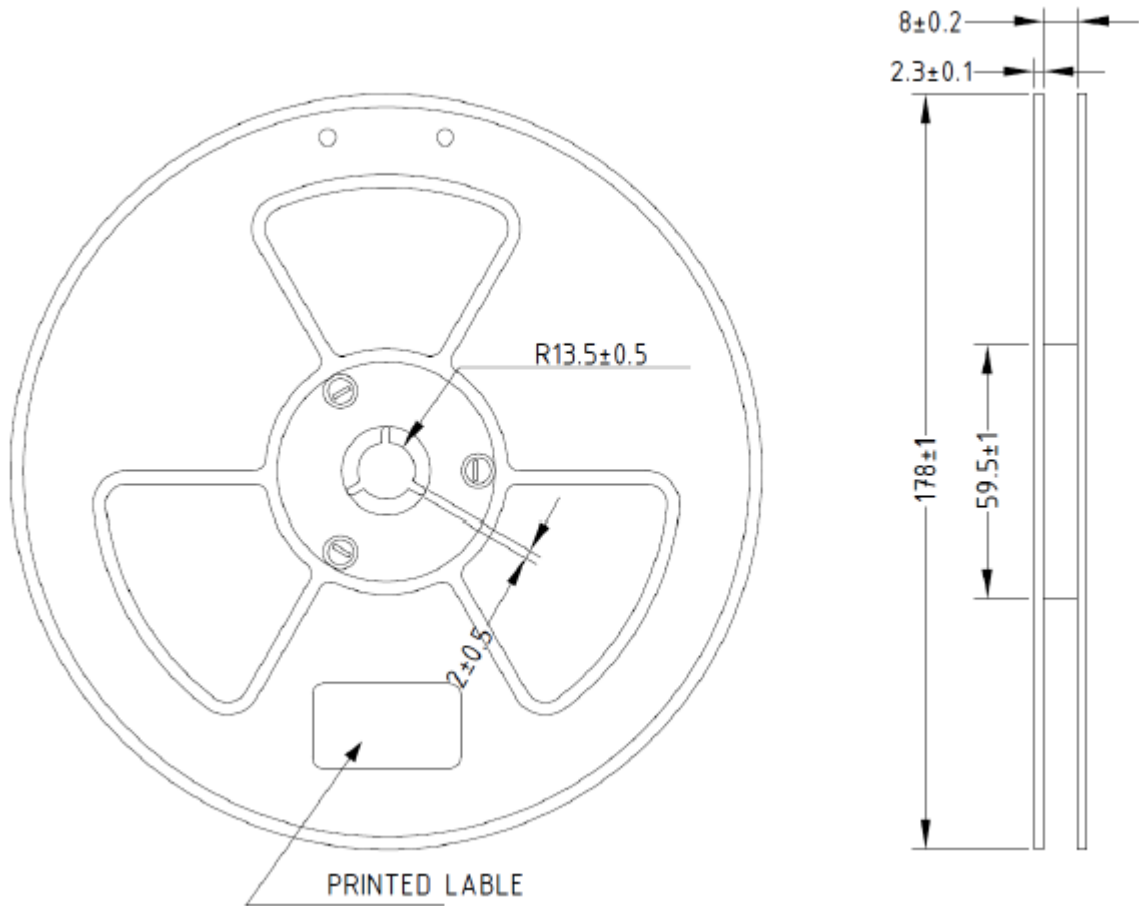

Note: Baking is required under the following conditions:
The pack has been opened for more than four weeks.
Baking recommended conditions:
 60 ± 5 °C for 20 hours.